

HOW TO BRACE YOUR WATER HEATER

All water heaters must be strapped in at least two locations; the upper one-third of the unit and the lower one-third. The lower strap must be a minimum of 4" above the water heater control unit. The required clearances from a wall to the heater as stated on the unit nameplate are critical.

Lag screws not less than 1/4" in diameter must be used to anchor the restraints to the wall and each lag screw must have at least 1-1/2" thread penetration into wall stud. A large flat washer must be installed between each lag screw and strap for reinforcement.

NOTE: Perforated iron strap (plumber's tape) will not be an acceptable material for strapping or bracing water heaters over 40 gallons.

The State of California requires that all water heaters must be strapped to resist motion during an earthquake. This may be accomplished by installing an over the counter "water heater restraint" kit approved by the Office of State Architect (O.S.A.).

Example (wrap-around straps):

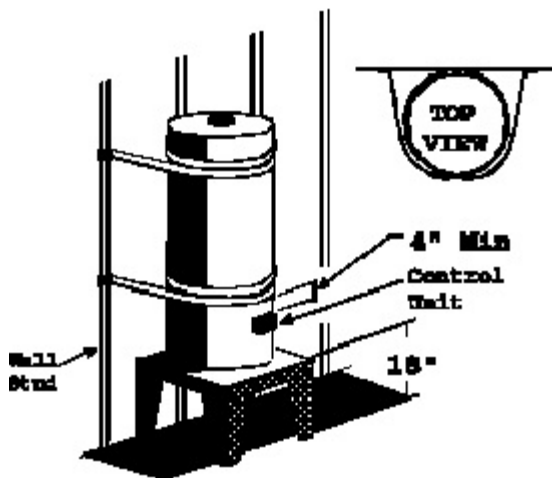

Drill pilot holes on the centerline of the stud (both sides of the heater), Insert screws through punched holes in the strap.

Use washers. Use minimum 22 Gauge X 3/4" wide metal strap.

